

# MATHEMATICS

*Maximum Marks: 80*

*Time allowed: Three hours*

1. *Answers to this Paper must be written on the paper provided separately.*
2. *You will not be allowed to write during first 15 minutes.*
3. *This time is to be spent in reading the question paper.*
4. *The time given at the head of this Paper is the time allowed for writing the answers.*
5. *Attempt all questions from Section A and any four questions from Section B.*
6. *All working, including rough work, must be clearly shown, and must be done on the same sheet as the rest of the answer.*
7. *Omission of essential working will result in loss of marks.*
8. *The intended marks for questions or parts of questions are given in brackets [ ]*
9. *Mathematical tables and graph papers are to be provided by the school.*

## *Instruction for the Supervising Examiner*

*Kindly read aloud the Instructions given above to all the candidates present in the Examination Hall.*

**This paper consists of 16 printed pages.**

## SECTION A (40 Marks)

(Attempt all questions from this Section.)

### Question 1

Choose the correct answers to the questions from the given options.

[15]

(Do not copy the questions, write the correct answers only.)

- (i) The given quadratic equation  $3x^2 + \sqrt{7}x + 2 = 0$  has:
- (a) two equal real roots.
  - (b) two distinct real roots.
  - (c) more than two real roots.
  - (d) no real roots.
- (ii) Mr. Anuj deposits ₹500 per month for 18 months in a recurring deposit account at a certain rate. If he earns ₹570 as interest at the time of maturity, then his matured amount is:
- (a) ₹(500 × 18 + 570)
  - (b) ₹(500 × 19 + 570)
  - (c) ₹(500 × 18 × 19 + 570)
  - (d) ₹(500 × 9 × 19 + 570)
- (iii) Which of the following cannot be the probability of any event?
- (a)  $\frac{5}{4}$
  - (b) 0.25
  - (c)  $\frac{1}{33}$
  - (d) 67%

(iv) The equation of the line passing through origin and parallel to the line  $3x + 4y + 7 = 0$  is:

- (a)  $3x + 4y + 5 = 0$
- (b)  $4x - 3y - 5 = 0$
- (c)  $4x - 3y = 0$
- (d)  $3x + 4y = 0$

(v) If  $A = \begin{bmatrix} 0 & 1 \\ 1 & 0 \end{bmatrix}$ , then  $A^2$  is equal to:

- (a)  $\begin{bmatrix} 1 & 1 \\ 0 & 0 \end{bmatrix}$
- (b)  $\begin{bmatrix} 0 & 0 \\ 1 & 1 \end{bmatrix}$
- (c)  $\begin{bmatrix} 1 & 0 \\ 0 & 1 \end{bmatrix}$
- (d)  $\begin{bmatrix} 0 & 1 \\ 1 & 0 \end{bmatrix}$

(vi) In the given diagram, chords  $AC$  and  $BC$  are equal. If  $\angle ACD = 120^\circ$ , then  $\angle AEC$  is:

- (a)  $30^\circ$
- (b)  $60^\circ$
- (c)  $90^\circ$
- (d)  $120^\circ$

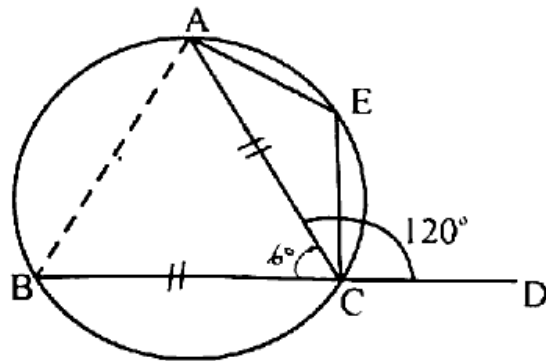

(vii) The factor **common** to the two polynomials  $x^2 - 4$  and  $x^3 - x^2 - 4x + 4$  is:

(a)  $(x + 1)$

(b)  $(x - 1)$

(c)  $(x + 2)$

(d)  $(x - 2)$

(viii) A man invested in a company paying 12% dividend on its share. If the percentage return on his investment is 10%, then the shares are:

(a) at par

(b) below par

(c) above par

(d) cannot be determined

(ix) **Statement 1:** The point which is equidistant from three non-collinear points **D, E** and **F** is the **circumcentre** of the  $\triangle DEF$ .

**Statement 2:** The **incentre** of a triangle is the point where the bisector of the angles intersect.

(a) Both the statements are true.

(b) Both the statements are false.

(c) Statement 1 is true, and Statement 2 is false.

(d) Statement 1 is false, and Statement 2 is true.

(x) **Assertion(A):** If  $\sin^2 A + \sin A = 1$  then  $\cos^4 A + \cos^2 A = 1$

**Reason(R):**  $1 - \sin^2 A = \cos^2 A$

(a) (A) is true, (R) is false.

(b) (A) is false, (R) is true.

(c) Both (A) and (R) are true, and (R) is the correct reason for (A).

(d) Both (A) and (R) are true, and (R) is the incorrect reason for (A).

(xi) In the given diagram  $\triangle ABC \sim \triangle EFG$ . If  $\angle ABC = \angle EFG = 60^\circ$ , then the length of the side FG is:

(a) 15 cm

(b) 20 cm

(c) 25 cm

(d) 30 cm

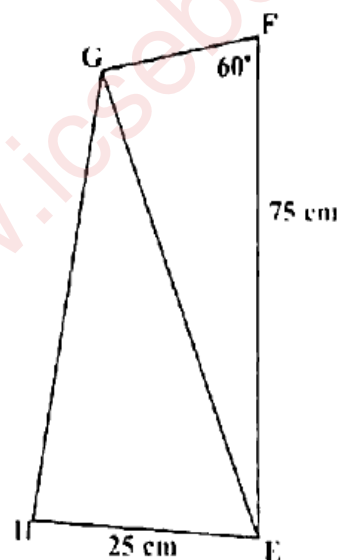
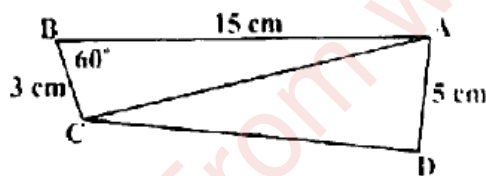

(xii) If the volume of two spheres is in the ratio 27 : 64, then the ratio of their radii is:

(a) 3 : 4

(b) 4 : 3

(c) 9 : 16

(d) 16 : 9

(xiii) The marked price of an article is ₹1375. If the CGST is charged at a rate of 4%, then the price of the article including GST is:

- (a) ₹55
- (b) ₹110
- (c) ₹1430
- (d) ₹1485

(xiv) The solution set for  $0 < -\frac{x}{3} < 2, x \in Z$  is:

- (a)  $\{-5, -4, -3, -2, -1\}$
- (b)  $\{-6, -5, -4, -3, -2, -1\}$
- (c)  $\{-5, -4, -3, -2, -1, 0\}$
- (d)  $\{-6, -5, -4, -3, -2, -1, 0\}$

(xv) **Assertion(A):** The mean of first 9 natural numbers is 4.5.

**Reason(R):** Mean =  $\frac{\text{Sum of all the observations}}{\text{Total number of observations}}$

- (a) (A) is true, (R) is false.
- (b) (A) is false, (R) is true.
- (c) Both (A) and (R) are true, and (R) is the correct reason for (A).
- (d) Both (A) and (R) are true, and (R) is the incorrect reason for (A).

### Question 2

(i) Solve the following quadratic equation  $2x^2 - 5x - 4 = 0$

Give your answer correct to three significant figures.

(Use mathematical tables for this question)

[4]

ii) Mrs. Rao deposited ₹250 per month in a recurring deposit account for a period of 3 years. She received ₹10,110 at the time of maturity. Find: [4]

- (a) the rate of interest  
(b) how much more interest Mrs. Rao will receive if she had deposited ₹50 more per month at the same rate of interest and for the same time.

(iii) In  $\triangle ABC$ ,  $\angle ABC = 90^\circ$ ,  $AB = 20$  cm,  $AC = 25$  cm,  $DE$  is perpendicular to  $AC$  such that  $\angle DEA = 90^\circ$  and  $DE = 3$  cm as shown in the given figure. [4]

- (a) Prove that  $\triangle ABC \sim \triangle AED$ .  
(b) Find the lengths of  $BC$ ,  $AD$  and  $AE$ .  
(c) If  $BCED$  represents a plot of land on a map whose actual area on ground is  $576$  m<sup>2</sup>, then find the scale factor of the map.

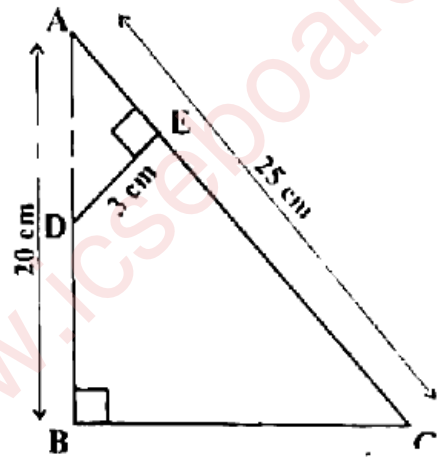

### Question 3

(i) Use ruler and compass for the following construction. Construct a  $\triangle ABC$ , where  $AB = 6$  cm,  $AC = 4.5$  cm and  $\angle BAC = 120^\circ$ . Construct a circle circumscribing the  $\triangle ABC$ . Measure and write down the length of the radius of the circle. *5.3 cm* [4]

(ii) If  $A = \begin{bmatrix} 1 & 2 \\ 3 & 4 \end{bmatrix}$ ,  $B = \begin{bmatrix} 2 & 1 \\ 4 & 2 \end{bmatrix}$  and  $C = \begin{bmatrix} -5 & 1 \\ 7 & -4 \end{bmatrix}$  [4]

Find:

- (a)  $A + C$   
(b)  $B(A+C)$   
(c)  $5I$   
(d)  $B(A+C) - 5B$

(iii) In the given graph ABCD is a parallelogram.

[5]

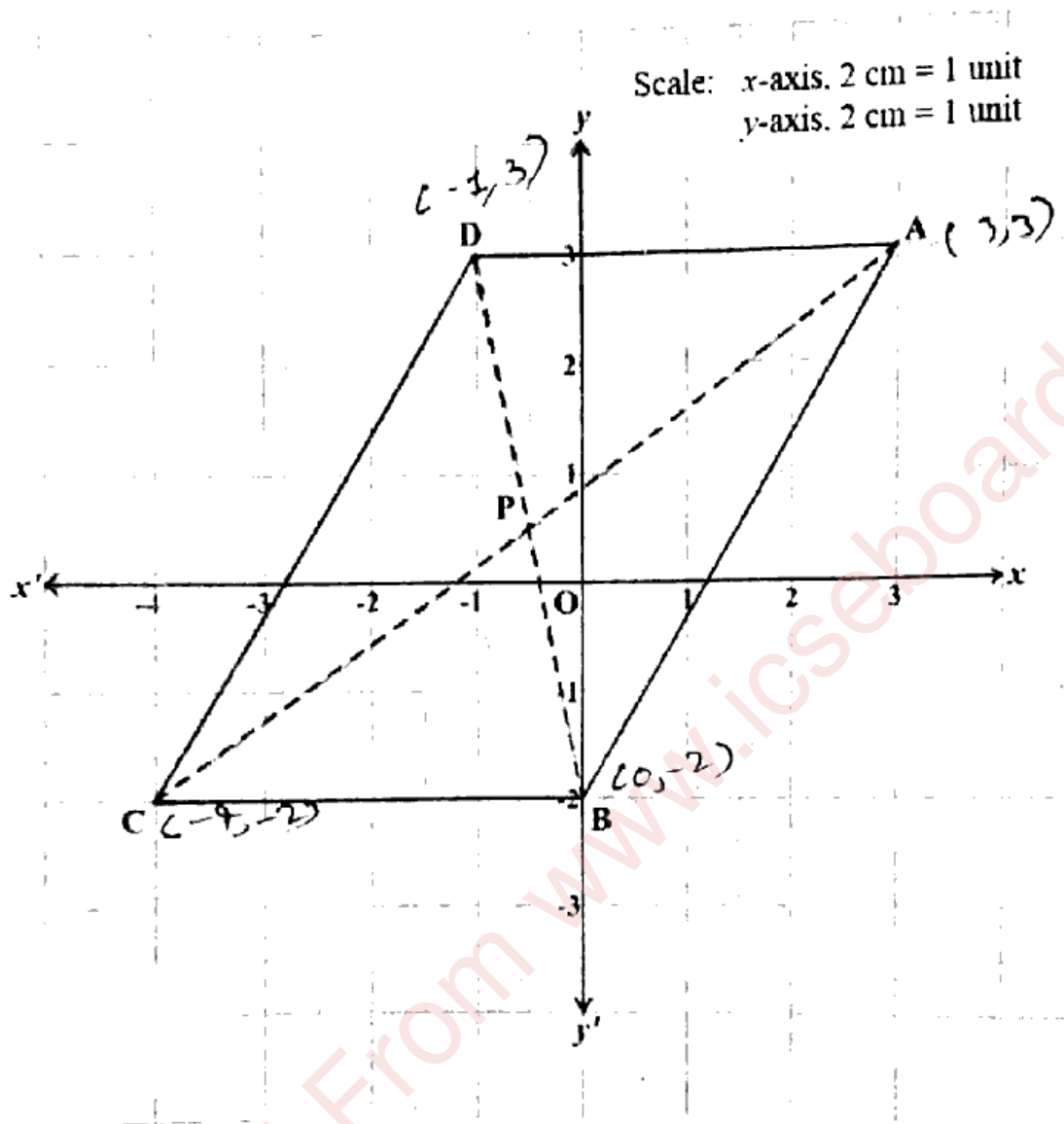

Using the graph, answer the following:

- write down the coordinates of A, B, C and D.
- calculate** the coordinates of 'P', the point of intersection of the diagonals AC and BD.
- find the slope of sides CB and DA and verify that they represent parallel lines.
- find the equation of the diagonal A

SECTION B (40 Marks)

(Attempt any four questions from this Section.)

Question 4

- (i) Solve the following inequation, write the solution set and represent it on the real number line. [3]

$$2x - \frac{5}{3} < \frac{3x}{5} + 10 \leq \frac{4x}{5} + 11; x \in \mathbb{R}$$

- (ii) The first term of an Arithmetic Progression (A.P.) is 5, the last term is 50 and their sum is 440. Find: [3]

(a) the number of terms  $n = 16$

(b) common difference  $d = 3$

- (iii) Prove that:

$$\frac{(\cot A + \tan A - 1)(\sin A + \cos A)}{\sin^3 A + \cos^3 A} = \sec A \cdot \operatorname{cosec} A$$

Question 5

- (i) Using properties of proportion, find the value of 'x': [3]

$$\frac{6x^2 + 3x - 5}{3x - 5} = \frac{9x^2 + 2x + 5}{2x + 5}; x \neq 0$$

- (ii) It is given that  $(x - 2)$  is a factor of polynomial  $2x^3 - 7x^2 + kx - 2$ . [3]

Find:

(a) the value of 'k'.

(b) hence, factorise the resulting polynomial completely.

- (iii) A solid wooden capsule is shown in **Figure 1**. The capsule is formed of a cylindrical block and two hemispheres. [4]

Find the **sum** of total surface area of the three parts as shown in **Figure 2**. Given, the radius of the capsule is **3.5 cm** and the length of the cylindrical block is **14 cm**.

(Use  $\pi = \frac{22}{7}$ )

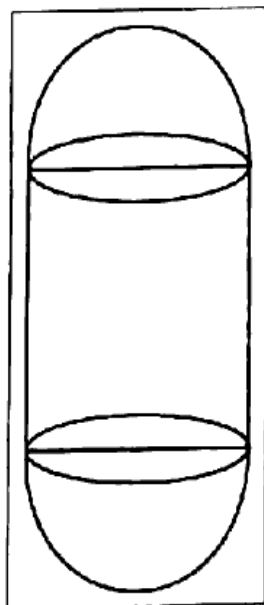

**Figure 1**

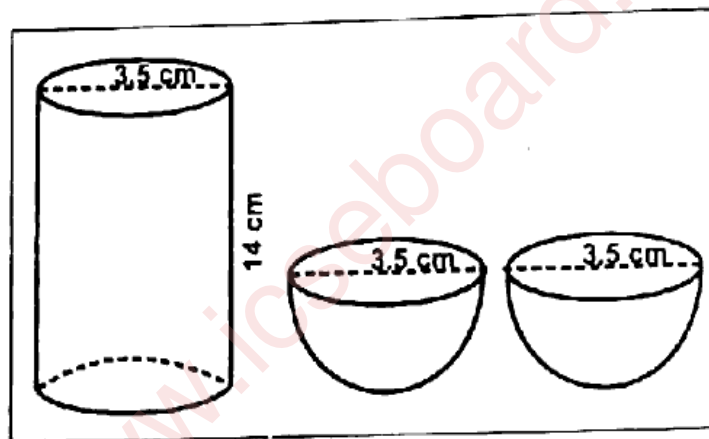

**Figure 2**

### Question 6

- (i) Use a graph paper for this question taking 2 cm = 1 unit along both axes. [8]
- Plot **A(1, 3)**, **B(1, 2)** and **C(3, 0)**.
  - Reflect **A** and **B** on the **x-axis** and name their images as **E** and **D** respectively. Write down their coordinates.
  - Reflect **A** and **B** through the **origin** and name their images as **F** and **G** respectively.
  - Reflect **A**, **B** and **C** on the **y-axis** and name their images as **J**, **I** and **H** respectively.
  - Join all the points **A, B, C, D, E, F, G, H, I** and **J** in order and name the closed figure so formed.

- (ii) In the given diagram, **AB** is a vertical tower 100 m away from the foot of a 30 storied building **CD**. The angles of depression from the point **C** and **E**, (**E** being the mid-point of **CD**), are  $35^\circ$  and  $14^\circ$  respectively. [5]

(Use mathematical table for the required values rounded off correct to two places of decimals only)

Find the height of the:

- (a) tower **AB**  
 (b) building **CD**

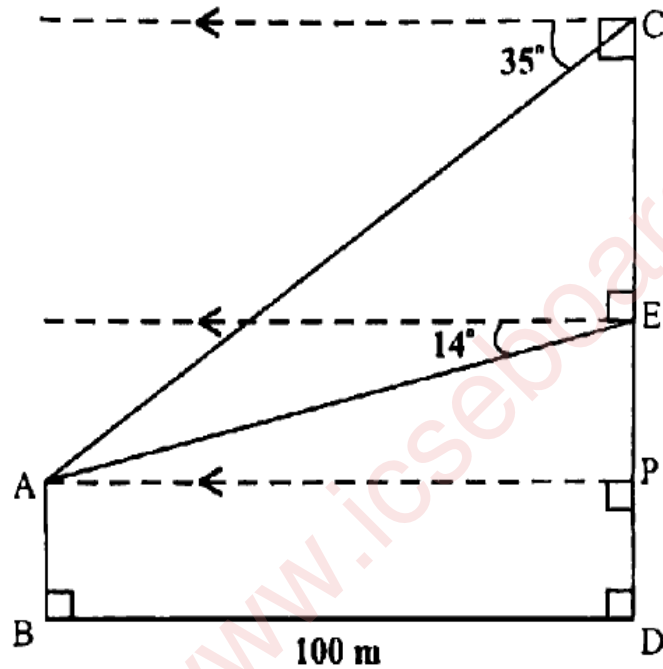

### Question 7

- (i) Use a graph paper for this question. [3]

(Take 2 cm = 10 Marks along one axis and 2 cm = 10 students along another axis).

Draw a Histogram for the following distribution which gives the marks obtained by 164 students in a particular class and hence find the **Mode**.

Marks	30 – 40	40 – 50	50 – 60	60 – 70	70 – 80
Number of Students	10	26	40	54	34

- (ii) In the given graph, **P** and **Q** are points such that **PQ** cuts off intercepts of **5 units** and **3 units** along the **x-axis** and **y-axis** respectively. Line **RS** is perpendicular to **PQ** and passes through the **origin**. Find the: [3]

- (a) coordinates of **P** and **Q**  
 (b) equation of line **RS**

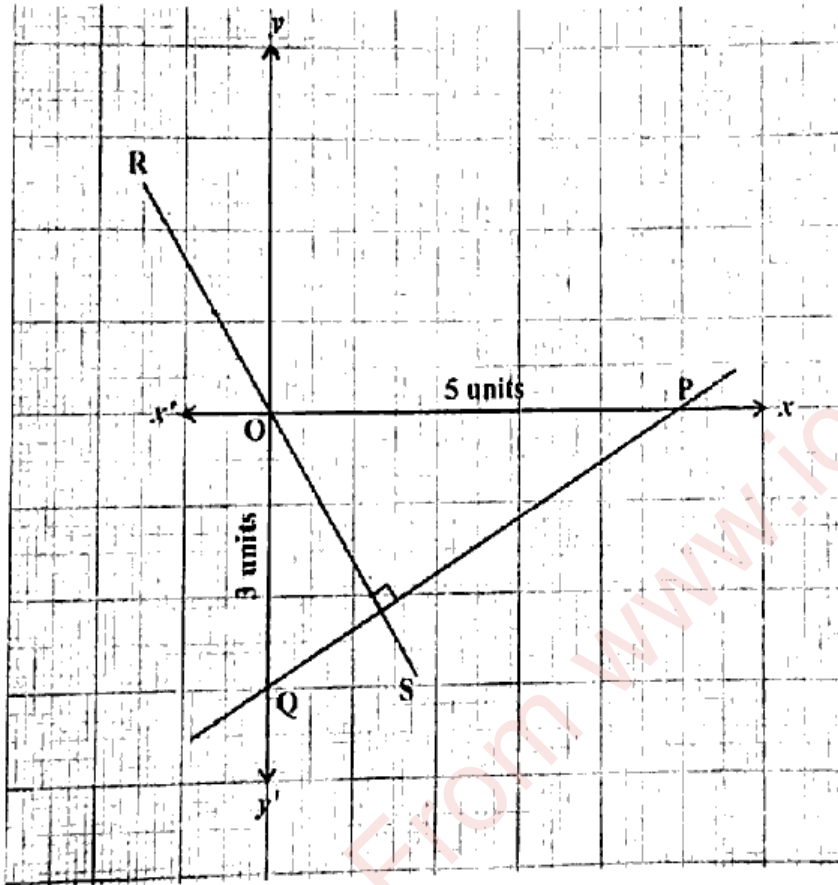

- (iii) Refer to the given bill. [4]

A customer paid ₹2000 (rounded off to the nearest ₹10) to clear the bill.

**Note:** 5% discount is applicable on an article if 10 or more such articles are purchased.

BILL			
Article	M.P. (₹)	Quantity	G.S.T.
A	190	06	12%
B	50	12	18%

Check whether the total amount paid by the customer is correct or not. Justify your answer with necessary working.

### Question 8

(i) A man bought ₹200 shares of a company at 25% premium. If he received a return of 5% on his investment. Find the [3]

- (a) market value.
- (b) dividend percent declared
- (c) number of shares purchased, if annual dividend is ₹1000.

(ii) For the given frequency distribution, find the: [3]

- (a) mean, to the nearest whole number-
- (b) median

$x$	10	11	12	13	14	15	16
$f$	3	2	2	6	3	5	3

(iii) Mr. and Mrs. Das were travelling by car from Delhi to Kasauli for a holiday. Distance between Delhi and Kasauli is approximately 350 km (via NH 152D). Due to heavy rain they had to slow down. The average speed of the car was reduced by 20 km/hr and time of the journey increased by 2 hours. Find [4]

- (a) the original speed of the car.
- (b) with the reduced speed, the number of hours they took to reach their destination.

### Question 9

- (i) A hollow sphere of external diameter 10 cm and internal diameter 6 cm is melted and made into a solid right circular cone of height 8 cm. Find the radius of the cone so formed. [3]

[Use  $\pi = \frac{22}{7}$ ]

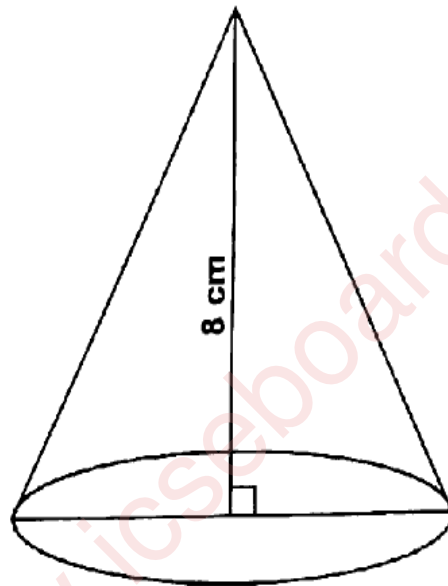
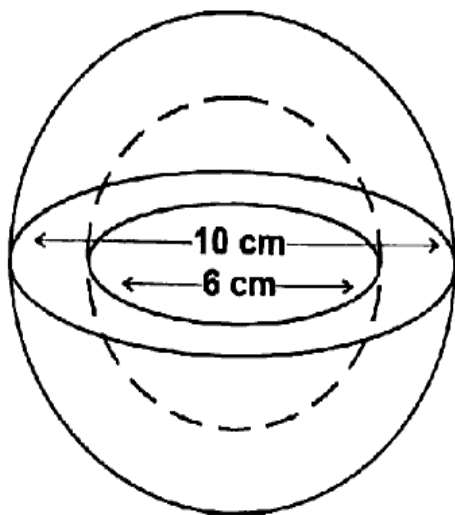

- (ii) Ms. Sushmita went to a fair and participated in a game. The game consisted of a box having number cards with numbers from 01 to 30. The three prizes were as per the given table: [3]

Prize	Number on the card drawn at random is a
Wall Clock	perfect square
Water Bottle	even number which is also a multiple of 3
Purse	prime number

Find the probability of winning a:

- (a) Wall Clock  
(b) Water Bottle  
(c) Purse

- (iii) X, Y, Z and C are the points on the circumference of a circle with centre 'O'. AB is a tangent to the circle at 'X' and  $ZY = XY$ . Given  $\angle OBX = 32^\circ$  and  $\angle AXZ = 66^\circ$ . Find: [4]

- (a)  $\angle BOX$   
 (b)  $\angle CYX$   
 (c)  $\angle ZYX$   
 (d)  $\angle OXY$

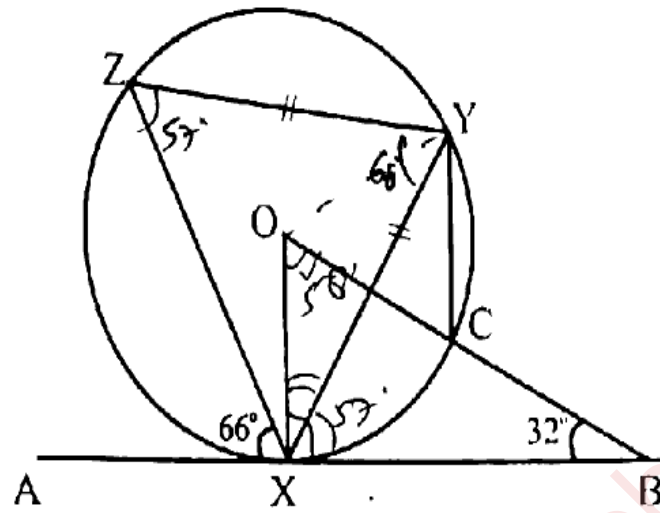

Question 10

- (i) If 1701 is the  $n^{\text{th}}$  term of the Geometric Progression (G.P.) 7, 21, 63 ... [3]

- (a) the value of 'n'  
 (b) hence find the sum of the 'n' terms of the G.P.

- (ii) In the given diagram 'O' is the centre of the circle. Chord SR produced meets the tangent XTP at P. [3]

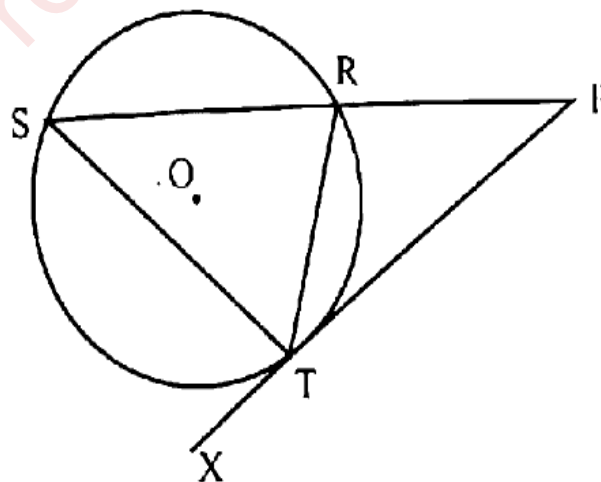

(a) Prove that  $\Delta PTR \sim \Delta PST$

(b) Prove that  $PT^2 = PR \times PS$

(c) If  $PR = 4 \text{ cm}$  and  $PS = 16 \text{ cm}$ , find the length of the tangent  $PT$

(iii) The given graph represents the monthly salaries (in ₹) of workers of a factory.

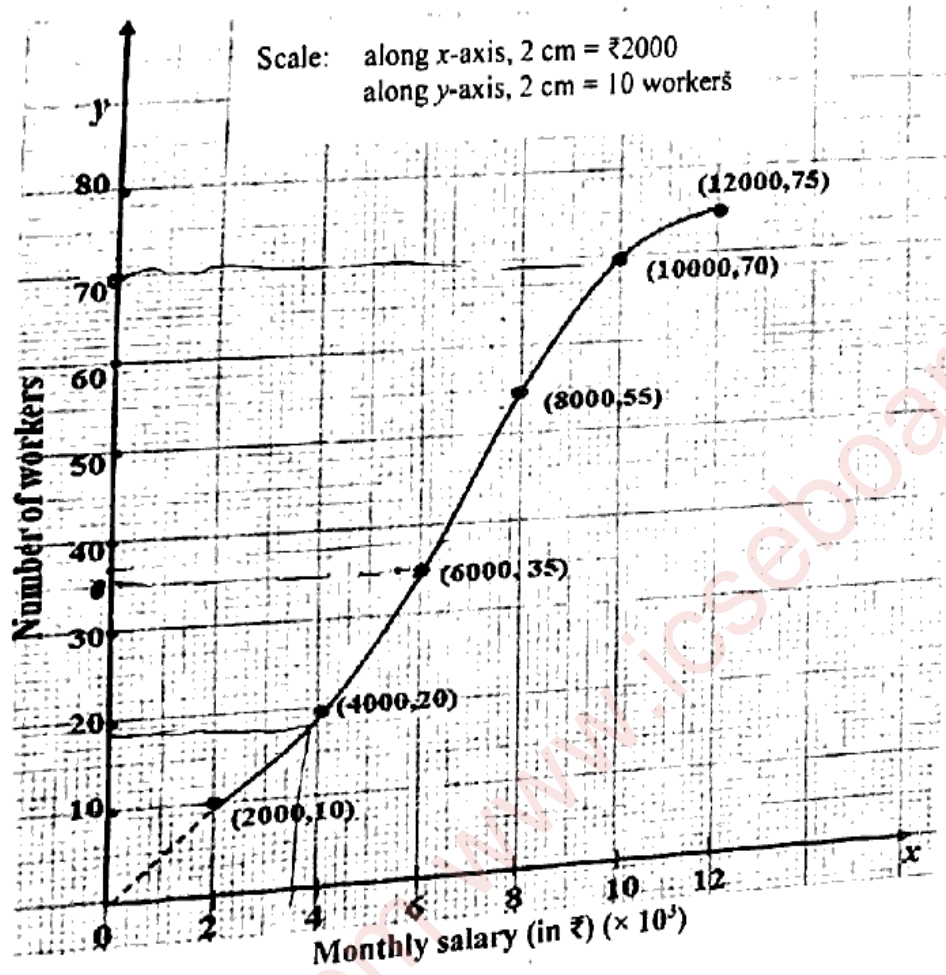

Using graph answer the following:

(a) the total number of workers.

(b) the median class.

(c) the lower-quartile class.

(d) number of workers having monthly salary more than or equal to ₹6,000 but less than ₹10,000.