MATHEMATICS

(Two hours and a half)

Answers to this Paper must be written on the paper provided separately.

*You will **not** be allowed to write during the first 15 minutes.*

This time is to be spent in reading the question paper.

The time given at the head of this Paper is the time allowed for writing the answers.

*Attempt **all** questions from **Section A** and **any four** questions from **Section B**.*

All working, including rough work, must be clearly shown and must be done on the same sheet as the rest of the answer.

Omission of essential working will result in loss of marks.

The intended marks for questions or parts of questions are given in brackets [].

Mathematical tables are provided.

SECTION A (40 Marks)

Attempt all questions from this Section.

Question 1

- (a) Solve the following Quadratic Equation: [3]

$$x^2 - 7x + 3 = 0$$

Give your answer correct to two decimal places.

- (b) Given $A = \begin{bmatrix} x & 3 \\ y & 3 \end{bmatrix}$ [3]

If $A^2 = 3I$, where I is the identity matrix of order 2, find x and y .

- (c) Using ruler and compass construct a triangle ABC where $AB = 3$ cm, $BC = 4$ cm and $\angle ABC = 90^\circ$. Hence construct a circle circumscribing the triangle ABC. Measure and write down the radius of the circle. [4]

This paper consists of 7 printed pages and 1 blank page.

Question 2

(a) Use factor theorem to factorise $6x^3 + 17x^2 + 4x - 12$ completely. [3]

(b) Solve the following inequation and represent the solution set on the number line. [3]

$$\frac{3x}{5} + 2 < x + 4 \leq \frac{x}{2} + 5, \quad x \in R$$

(c) Draw a Histogram for the given data, using a graph paper: [4]

Weekly Wages (in ₹)	No. of People
3000 – 4000	4
4000 – 5000	9
5000 – 6000	18
6000 – 7000	6
7000 – 8000	7
8000 – 9000	2
9000 – 10000	4

Estimate the mode from the graph.

Question 3

(a) In the figure given below, O is the centre of the circle and AB is a diameter. [3]

If $AC = BD$ and $\angle AOC = 72^\circ$. Find:

(i) $\angle ABC$

(ii) $\angle BAD$

(iii) $\angle ABD$

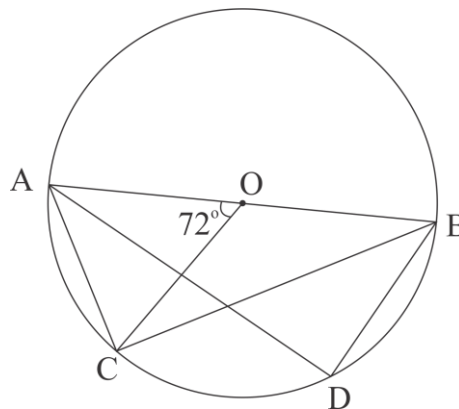

(b) Prove that: [3]

$$\frac{\sin A}{1 + \cot A} - \frac{\cos A}{1 + \tan A} = \sin A - \cos A$$

(c) In what ratio is the line joining P(5, 3) and Q(-5, 3) divided by the y-axis? Also find the coordinates of the point of intersection. [4]

Question 4

- (a) A solid spherical ball of radius 6 cm is melted and recast into 64 identical spherical marbles. Find the radius of each marble. [3]
- (b) Each of the letters of the word 'AUTHORIZES' is written on identical circular discs and put in a bag. They are well shuffled. If a disc is drawn at random from the bag, what is the probability that the letter is: [3]
- (i) a vowel
 - (ii) one of the first 9 letters of the English alphabet which appears in the given word
 - (iii) one of the last 9 letters of the English alphabet which appears in the given word?
- (c) Mr. Bedi visits the market and buys the following articles: [4]
- Medicines costing ₹ 950, GST @ 5%
- A pair of shoes costing ₹ 3000, GST @ 18%
- A Laptop bag costing ₹ 1000 with a discount of 30%, GST @ 18%.
- (i) Calculate the total amount of GST paid.
 - (ii) The total bill amount including GST paid by Mr. Bedi.

SECTION B (40 Marks)

Attempt any four questions from this Section

Question 5

- (a) A company with 500 shares of nominal value ₹ 120 declares an annual dividend of 15%. Calculate: [3]
- (i) the total amount of dividend paid by the company.
 - (ii) annual income of Mr. Sharma who holds 80 shares of the company.
- If the return percent of Mr. Sharma from his shares is 10%, find the market value of each share.

- (b) The mean of the following data is 16. Calculate the value of f . [3]

Marks	5	10	15	20	25
No. of Students	3	7	f	9	6

- (c) The 4th, 6th and the last term of a geometric progression are 10, 40 and 640 respectively. If the common ratio is positive, find the first term, common ratio and the number of terms of the series. [4]

Question 6

- (a) If $A = \begin{bmatrix} 3 & 0 \\ 5 & 1 \end{bmatrix}$ and $B = \begin{bmatrix} -4 & 2 \\ 1 & 0 \end{bmatrix}$ [3]

Find $A^2 - 2AB + B^2$

- (b) In the given figure $AB = 9$ cm, $PA = 7.5$ cm and $PC = 5$ cm. [3]
Chords AD and BC intersect at P .

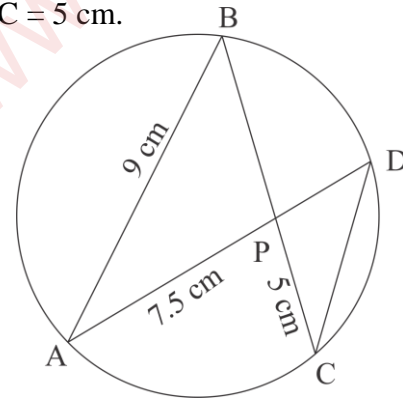

- (i) Prove that $\Delta PAB \sim \Delta PCD$
(ii) Find the length of CD .
(iii) Find area of ΔPAB : area of ΔPCD
- (c) From the top of a cliff, the angle of depression of the top and bottom of a tower are observed to be 45° and 60° respectively. If the height of the tower is 20 m. [4]

Find:

- (i) the height of the cliff
(ii) the distance between the cliff and the tower.

Question 7

- (a) Find the value of ' p ' if the lines, $5x - 3y + 2 = 0$ and $6x - py + 7 = 0$ are perpendicular to each other. Hence find the equation of a line passing through $(-2, -1)$ and parallel to $6x - py + 7 = 0$. [3]

- (b) Using properties of proportion find $x : y$, given: [3]

$$\frac{x^2 + 2x}{2x + 4} = \frac{y^2 + 3y}{3y + 9}$$

- (c) In the given figure TP and TQ are two tangents to the circle with centre O, touching at A and C respectively. If $\angle BCQ = 55^\circ$ and $\angle BAP = 60^\circ$, find: [4]

- (i) $\angle OBA$ and $\angle OBC$
 (ii) $\angle AOC$
 (iii) $\angle ATC$

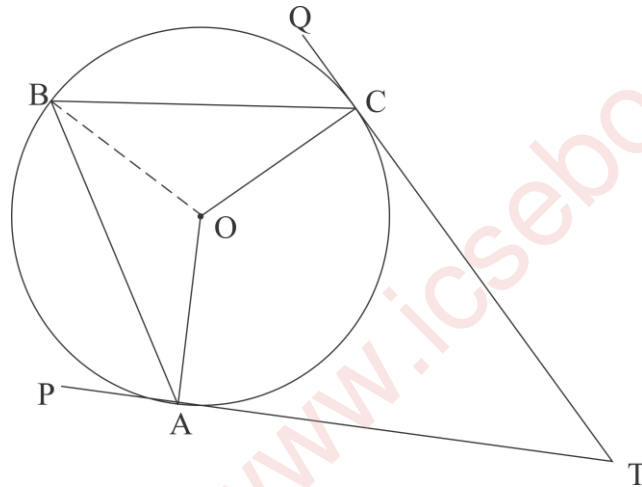

Question 8

- (a) What must be added to the polynomial $2x^3 - 3x^2 - 8x$, so that it leaves a remainder 10 when divided by $2x + 1$? [3]
- (b) Mr.Sonu has a recurring deposit account and deposits ₹ 750 per month for 2 years. If he gets ₹ 19125 at the time of maturity, find the rate of interest. [3]
- (c) Use graph paper for this question. [4]

Take 1 cm = 1 unit on both x and y axes.

- (i) Plot the following points on your graph sheets:
 $A(-4, 0)$, $B(-3, 2)$, $C(0, 4)$, $D(4, 1)$ and $E(7, 3)$
- (ii) Reflect the points B, C, D and E on the x -axis and name them as B', C', D' and E' respectively.
- (iii) Join the points A, B, C, D, E, E', D', C', B' and A in order.
- (iv) Name the closed figure formed.

Question 9

- (a) 40 students enter for a game of shot-put competition. The distance thrown (in metres) is recorded below: [6]

Distance in m	12 – 13	13 – 14	14 – 15	15 – 16	16 – 17	17 – 18	18 – 19
Number of Students	3	9	12	9	4	2	1

Use a graph paper to draw an ogive for the above distribution.

Use a scale of 2 cm = 1 m on one axis and 2 cm = 5 students on the other axis.

Hence using your graph find:

- the median
 - Upper Quartile
 - Number of students who cover a distance which is above $16\frac{1}{2}$ m.
- (b) If $x = \frac{\sqrt{2a+1} + \sqrt{2a-1}}{\sqrt{2a+1} - \sqrt{2a-1}}$, prove that $x^2 - 4ax + 1 = 0$ [4]

Question 10

- (a) If the 6th term of an A.P. is equal to four times its first term and the sum of first six terms is 75, find the first term and the common difference. [3]
- (b) The difference of two natural numbers is 7 and their product is 450. [3]
Find the numbers.
- (c) Use ruler and compass for this question. Construct a circle of radius 4.5 cm. [4]
Draw a chord. AB = 6 cm.
- Find the locus of points equidistant from A and B.
Mark the point where it meets the circle as D.
 - Join AD and find the locus of points which are equidistant from AD and AB.
Mark the point where it meets the circle as C.
 - Join BC and CD. Measure and write down the length of side CD of the quadrilateral ABCD.

Question 11

- (a) A model of a high rise building is made to a scale of 1 : 50. [3]
- (i) If the height of the model is 0.8 m, find the height of the actual building.
- (ii) If the floor area of a flat in the building is 20 m^2 , find the floor area of that in the model.
- (b) From a solid wooden cylinder of height 28 cm and diameter 6 cm, two conical cavities are hollowed out. The diameters of the cones are also of 6 cm and height 10.5 cm. [3]

Taking $\pi = \frac{22}{7}$ find the volume of the remaining solid.

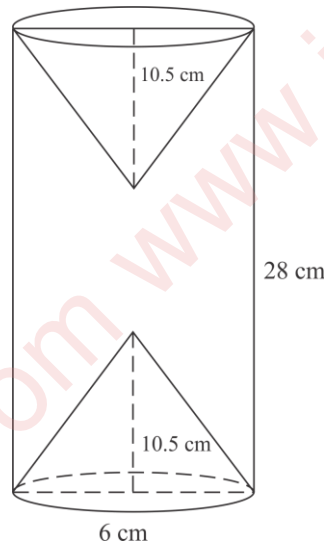

- (c) Prove the identity [4]

$$\left(\frac{1 - \tan \theta}{1 - \cot \theta} \right)^2 = \tan^2 \theta$$