

CHEMISTRY
(SCIENCE PAPER – 2)

Maximum Marks: 80

Time allowed: Two hours

1. *Answers to this Paper must be written on the paper provided separately.*
 2. *You will **not** be allowed to write during first 15 minutes.*
 3. *This time is to be spent in reading the question paper.*
 4. *The time given at the head of this Paper is the time allowed for writing the answers.*
-
5. *Section A is compulsory. Attempt any four questions from Section B.*
 6. *The intended marks for questions or parts of questions are given in brackets [].*

Instruction for the Supervising Examiner

Kindly read aloud the Instructions given above to all the candidates present in the Examination Hall.

SECTION A (40 Marks)

*(Attempt **all** questions from this **Section**.)*

Question 1

Choose the correct answers to the questions from the given options. [15]

(Do not copy the questions, write the correct answers only.)

(i) Read the statements given below:

I – Copper is a component in the alloy that is used to make medals.

II – Aluminium is used in making the alloy stainless steel.

III – Copper is a common component of both duralumin and brass.

Which of the statements are correct?

(a) I & II

(b) I & III

(c) II & III

(d) I, II & III

(ii) Sodium hydroxide can react with _____ acid to form an acid salt.

(a) Nitric acid

(b) Hydrochloric acid

(c) Acetic acid

(d) Sulphuric acid

(iii) How many moles are present in 10g of CaCO_3 ?

[Atomic weight: $\text{Ca} = 40$, $\text{C} = 12$, $\text{O} = 16$]

- (a) 10 moles
- (b) 1 mole
- (c) 0.1 mole
- (d) 0.11 mole

(iv) A white precipitate is formed when dilute hydrochloric acid reacts with 'X'. The white precipitate is soluble in excess of NH_4OH and insoluble in dilute HNO_3 . Identify 'X'.

- (a) AgNO_3
- (b) NH_4Cl
- (c) AgCl
- (d) CaCl_2

(v) **Assertion (A):** In a solution containing equal concentration of Cu^{+2} ions and Ca^{+2} ions, Cu^{+2} ions will be discharged in preference to Ca^{+2} ions.

Reason (R): Ca^{+2} ions are placed above Cu^{+2} ions in the electrochemical series.

- (a) Both (A) and (R) are true, and (R) is the correct explanation of (A).
- (b) Both (A) and (R) are true, and (R) is not the correct explanation of (A).
- (c) (A) is true but (R) is false.
- (d) (A) is false but (R) is true.

(vi) **Assertion (A):** Hydraulic washing is a method to separate impurities from the ore.

Reason (R): In Hydraulic washing, denser particles float and lighter particles settle down.

- (a) Both (A) and (R) are true and (R) is the correct explanation of (A).
- (b) Both (A) and (R) are true and (R) is not the correct explanation of (A).
- (c) (A) is true but (R) is false.
- (d) (A) is false but (R) is true.

(vii) The oxide which reacts with both dilute hydrochloric acid and sodium hydroxide solution to form salt and water is:

- (a) Basic oxide
- (b) Amphoteric oxide
- (c) Acidic oxide
- (d) Neutral oxide

(viii) Which of the following will occupy the volume 2.8 litres at S.T.P.?

(Atomic weight: $C = 12$, $O = 16$, $Cl = 35.5$, $S = 32$)

- (a) 2 moles of carbon dioxide
- (b) 7.1 g of chlorine
- (c) 8 g of sulphur dioxide
- (d) 56 g of carbon monoxide

(ix) A salt solution which gives a reddish-brown precipitate with NaOH and a white precipitate with BaCl₂ solution is:

- (a) CuSO₄
- (b) Ca(NO₃)₂
- (c) Fe₂(SO₄)₃
- (d) FeCl₃

(x) An alkane with molecular mass 44 is:

- (a) CH₄
- (b) C₃H₈
- (c) C₄H₁₀
- (d) C₂H₆

(xi) The gas evolved in the diagrammatic set up given below turns calcium hydroxide solution milky. The gas evolved is:

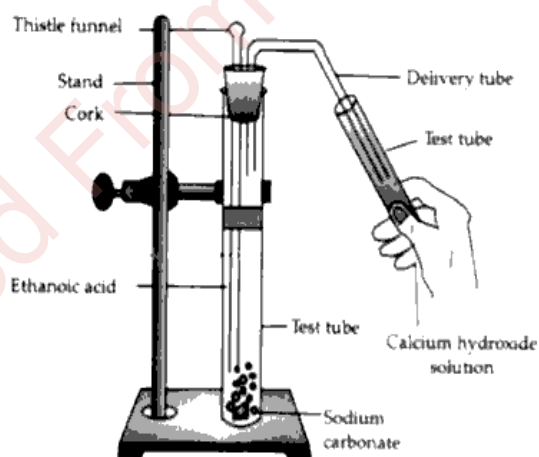

- (a) CH₄
- (b) C₂H₆
- (c) CO₂
- (d) SO₂

- (xii) Which gas is evolved when ammonia gas is passed over buff yellow PbO ?
- (a) N_2O
 - (b) NO
 - (c) N_2
 - (d) NO_2
- (xiii) Three different solutions **X** (sodium chloride solution), **Y** (acetic acid) and **Z** (sugar solution) were used for electrolysis by a student. When the circuit was completed, he noticed that the bulb glowed in the electrolytic cell containing:
- (a) X & Y
 - (b) Y & Z
 - (c) Z & X
 - (d) X, Y & Z
- (xiv) An element **X** has an electronic configuration 2, 2. The compound formed when **X** combines with oxygen is most likely to be:
- (a) a compound with a low melting point.
 - (b) a gas that dissolves in water to form an electrolyte.
 - (c) a good conductor in both solid and molten state.
 - (d) an ionic solid.
- (xv) If an element has a low ionisation potential, it is most likely to be a:
- (a) metal
 - (b) non-metal
 - (c) metalloid
 - (d) inert gas

Question 2

(i)

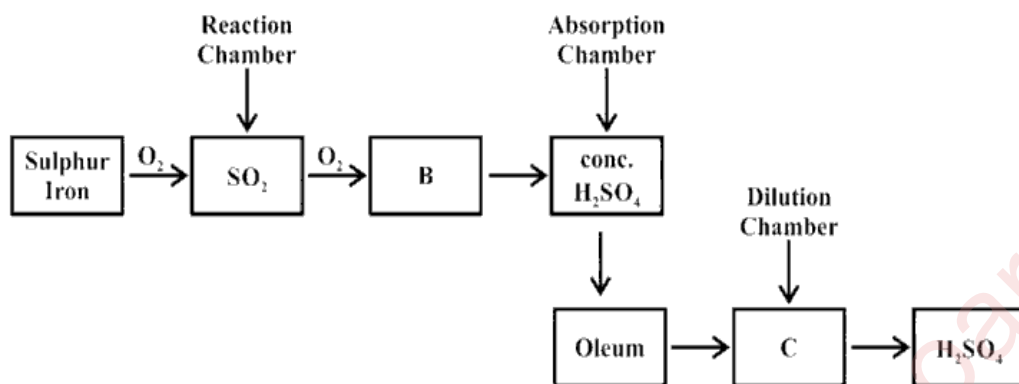

[5]

(a) Balance the chemical equation given below:

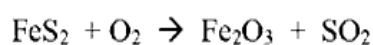

(b) Write balanced chemical equation for formation of 'B'.

(c) Why is it necessary to convert 'B' to Oleum?

(d) Identify 'C'.

(e) Write an equation for the reaction between Oleum and 'C'.

(ii) Ammonium hydroxide solution is added to the solution containing the ions mentioned in List X. List Y gives the details of the precipitate. Match the ions with their coloured precipitates.

[5]

List X	List Y
(a) Zn^{2+}	1. No visible reaction
(b) Fe^{2+}	2. White precipitate insoluble in excess
(c) Pb^{2+}	3. Gelatinous white precipitate soluble in excess
(d) Fe^{3+}	4. Blue precipitate soluble in excess
(e) Ca^{2+}	5. Dirty green precipitate insoluble in excess
	6. Reddish brown precipitate insoluble in excess

(iii) Complete the following sentences by choosing the correct answer from the brackets: [5]

- (a) The metal to be refined is kept at the _____ during the process of electro-refining. [*cathode / anode*]
- (b) Dilute HCl and dilute H₂SO₄ can be distinguished by adding _____ solution. [*NaNO₃ / BaCl₂*]
- (c) Ammonia gas is collected by _____ displacement of air. [*upward / downward*]
- (d) The gas formed when copper carbonate is heated is _____. [*O₂ / CO₂*]
- (e) Excess ammonia reacts with chlorine to form _____. [*nitrogen / nitrogen trichloride*]

(iv) State the **terms** for the following: [5]

- (a) A substance which when dissolved in water forms hydronium ion as the only positive ion.
- (b) A type of covalent bond in which electrons are shared equally between the combining atoms.
- (c) The process by which a base metal is coated with another metal, either to protect the metal or to give it an attractive appearance.
- (d) The type of reaction characteristic for alkanes.
- (e) The substance which oxidises the other substance and itself gets reduced.

(v) (a) Draw the structural diagram for the following organic compounds: [5]

1. bromoethane
2. methanal
3. but-2-yne

(b) Give IUPAC name for the following organic compounds:

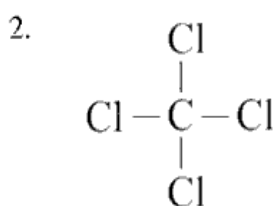
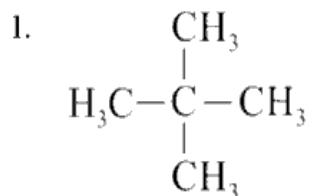

SECTION B (40 Marks)

(Attempt any four questions from this Section.)

Question 3

(i) In the given equation [2]

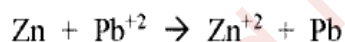

(a) _____ undergoes oxidation.

(b) _____ undergoes reduction.

(ii) Justify the following statements: [2]

(a) As one moves down a group, the reducing property of elements increases.

(b) Aluminium oxide cannot be reduced by carbon monoxide.

- (iii) Arrange the following as per the instructions given in the brackets: [3]
- (a) Mg, S, Si, P [decreasing order of atomic size]
- (b) Cl, I, Br, F [increasing electronegativity]
- (c) K, Na, Rb, Li [decreasing metallic character]
- (iv) Harsh performed the following experiments in the laboratory. State **one significant observation** made by Harsh when: [3]
- (a) he added concentrated sulphuric acid to blue vitriol.
- (b) he passed ammonia gas over heated PbO.
- (c) sodium hydroxide solution was added to CuSO₄ solution by him.

Question 4

- (i) Choose the letters **L, M, N, O & P** to match the description (a) to (c) given below: [3]
- [L – Ammonia, M – Nitrogen, N – Hydrogen sulphide
O – Hydrogenchloride gas, P – Nitrogen dioxide]
- (a) When this gas comes in contact with ammonia dense white fumes are seen.
- (b) The gas that turns moist lead acetate paper silvery black.
- (c) The gas produced on heating lead nitrate.
- (ii) Smith wrote the following statements incorrectly. Insert a word to correct the statements. [3]
- (a) Lead bromide conducts electricity.
- (b) Copper reacts with nitric acid to form nitrogen dioxide gas.
- (c) Bromoethane reacts with sodium hydroxide to produce ethanol and sodium bromide.

- (iii) Match the Column A (showing the properties of H_2SO_4) with Column B (showing the reaction of H_2SO_4) [4]

Column A Properties of H_2SO_4	Column B Reaction of H_2SO_4
(a) Acidic property	1. $\text{C}_{12}\text{H}_{22}\text{O}_{11} + n\text{H}_2\text{SO}_4 \rightarrow 12\text{C} + 11\text{H}_2\text{O} + n\text{H}_2\text{SO}_4$
(b) Dehydrating property	2. $\text{S} + 2\text{H}_2\text{SO}_4 \rightarrow 3\text{SO}_2 + 2\text{H}_2\text{O}$
(c) Non-volatile acid	3. $\text{CaO} + \text{H}_2\text{SO}_4 \rightarrow \text{CaSO}_4 + \text{H}_2\text{O}$
(d) Oxidizing agent	4. $\text{NaCl} + \text{H}_2\text{SO}_4 \rightarrow \text{NaHSO}_4 + \text{HCl}$

Question 5

- (i) Calcium oxide is a drying agent which removes water vapour. [2]

A student wanted to collect a dry sample of the hydrogen chloride gas produced. The student set up the apparatus as shown below but was unsuccessful in collecting any gas.

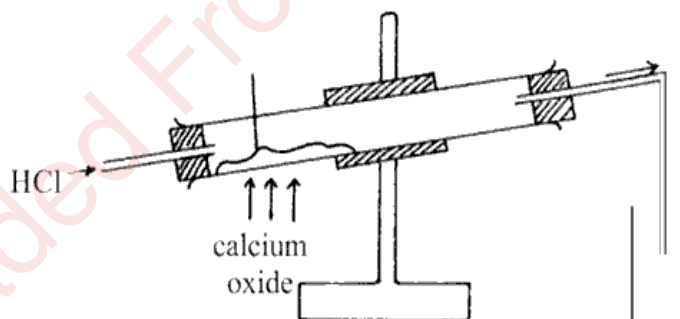

- (a) What mistake did the student make?
- (b) What change should be made by the student in order to collect the dry HCl gas?

(ii) Select the correct answer from the options given in the brackets: [2]

(a) The ion which is discharged at the cathode during the electrolysis of CuSO_4 solution using copper electrodes. [Cu^{+2} , OH^- , SO_4^{2-} , H^+]

(b) During electroplating of an article with Ag using sodium argentocyanide as an electrolyte, the anode is made of. [Cu , Ag , Pt , Na]

(iii) Ethane C_2H_6 burns in oxygen to produce carbon dioxide and water as shown in the equation given below: [3]

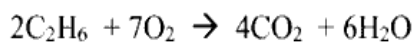

Calculate the composition of the resulting gaseous mixture at room temperature when 60 c.c. of ethane burns in 250 c.c. of oxygen.

(iv) Match the uses of alloys in **List 1** with the appropriate answer from **List 2**. [3]

List 1	List 2
(a) Used in making decorative articles.	1. Stainless steel
(b) An alloy used in making aircraft and light tools.	2. Brass
(c) Used in making surgical Instruments.	3. Duralumin

Question 6

(i) You are provided with some compounds in the box. [3]

SO_2 , PbO , CO , K_2SO_4 , H_2SO_4 , CH_3COOH , NaHSO_4 , KCl
--

Choose the compound from the above box that fits the descriptions from (a) to (c).

(a) An acid present in vinegar.

(b) An oxide which dissolves in water forming an acid.

(c) A salt formed by the incomplete neutralization of an acid by a base.

(ii) Draw the dot and cross structure of the following: [3]

- (a) Hydronium ion
- (b) Oxygen molecule
- (c) Calcium oxide

[Atomic number: $H = 1$, $O = 8$, $Ca = 20$]

(iii) Given below is the diagram for the laboratory preparation of Nitric Acid. [4]

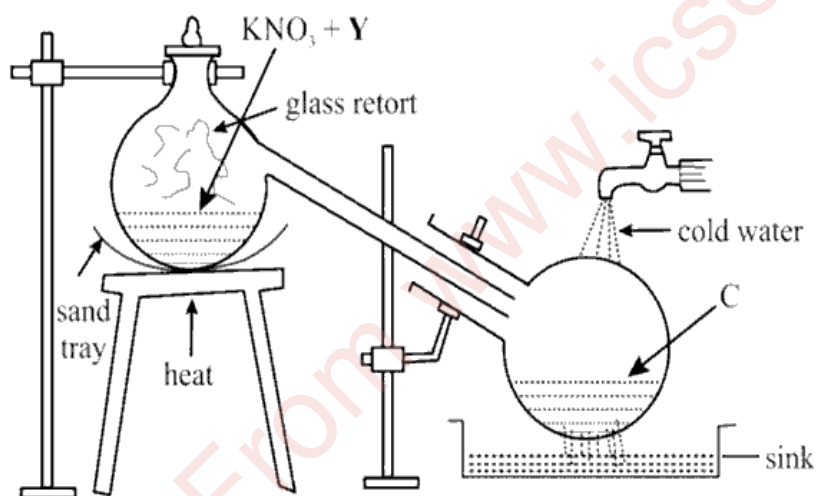

- (a) Name the reactant labelled Y.
- (b) Write a balanced equation for the reaction between Y and KNO_3 .
- (c) The complete apparatus is made up of glass. Why?
- (d) State why concentrated HNO_3 appears slightly yellowish in colour when left standing in a glass bottle for a long time.

Question 7

- (i) Answer the following questions related to the electrolytic reduction of pure Alumina [2]
by Hall Heroult's process.
- (a) The reaction occurring at the anode.
 - (b) The reaction occurring at the cathode.
- (ii) Give the chemical formula of the following ores: [2]
- (a) Cryolite
 - (b) Haemetite
- (iii) Write the balanced equations for the following reactions: [3]
- (a) Potassium bicarbonate reacts with dilute HCl.
 - (b) Laboratory preparation of ethane using soda lime.
 - (c) Warm water is added to Aluminium nitride.
- (iv) Nitrogen and hydrogen combine in the presence of a catalyst to give ammonia gas. [3]
With reference to the above reaction:
- (a) Name the catalyst used.
 - (b) At what temperature does the above reaction occur?
 - (c) What optimum pressure should be maintained during the reaction?

Question 8

- (i) 1 mole of CO_2 occupies 24 dm^3 at room temperature and pressure. [2]

Calculate the following:

- (a) The mass of 6 litres of CO_2 .
(b) The volume occupied by 60 g of CO_2 .

[Atomic weight: $\text{C}=12$, $\text{O}=16$]

- (ii) Define: [2]

- (a) Electrolyte
(b) Catenation

- (iii) Name the most appropriate method of preparation of the following salts: [3]

- (a) Copper carbonate
(b) Sodium sulphate
(c) Ferric chloride

- (iv) Complete and balance the following equation: [3]

