

TECHNICAL DRAWING APPLICATIONS

Maximum Marks: 100

Time allowed: Three hours

Answers to this Paper must be written on the paper provided separately.

*You will **not** be allowed to write during the first 15 minutes.*

This time is to be spent in reading the question paper.

The time given at the head of this Paper is the time allowed for writing the answers.

*Attempt **five** questions in all.*

*You must attempt **three** questions from **Section A** and **two** questions from **Section B**.*

Each section should be answered on a separate paper.

All questions must be answered in full scale.

All construction lines must be shown.

All dimensions are in millimeters unless specified otherwise.

The intended marks for questions or parts of questions are given in brackets [].

SECTION A (48 Marks)

*Answer any **three** questions from this Section.*

Question 1

(i) Construct a square of side 30 mm. Construct four equal circles outside this square, [16]
each touching one side of the square and two other circles externally.

(ii) Construct a Parabola by Rectangle Method.

Given: Base = 140 mm and Axis height = 90 mm.

Question 2

On a map, a line measuring 8 cm represents a distance of 15 dm. Calculate the R.F. [16]

Construct a suitable scale having the same R.F. and long enough to measure 2.84 metres.

Show the data and the working neatly.

Taking the measurements from the scale constructed, draw a quadrilateral ABCD.

Given: $BC = 2.58$ m, $\angle ABC = 45^\circ$, $AB = 1.63$ m and $AD = CD = 1.06$ m

Question 3

Refer to Figure 1 given below. [16]

Copy the given template.

(Insert any six dimensions.)

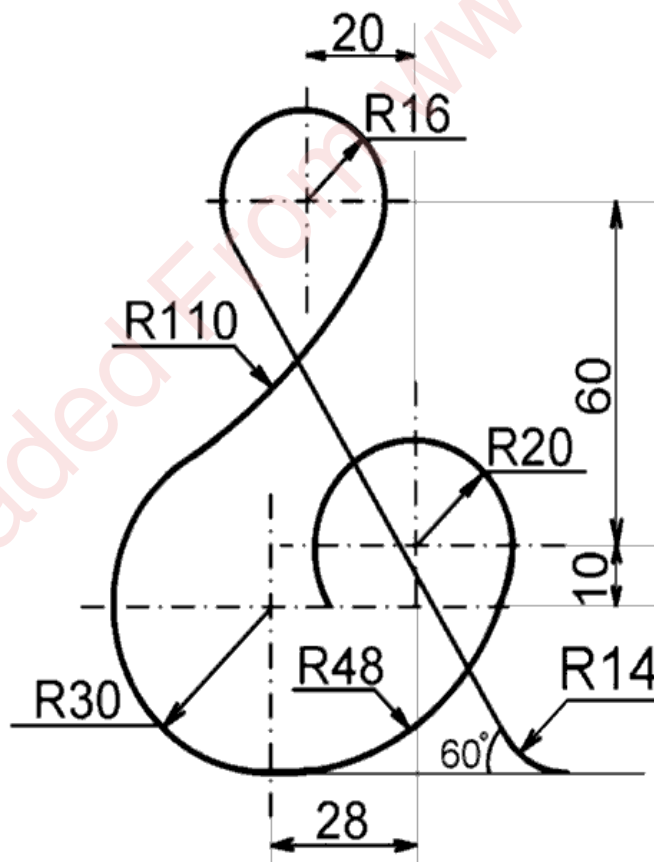

Figure 1

Question 4

Draw the Front View, Top View and the Left Hand Side View of a right hexagonal pyramid which has its axis inclined at 60° to the vertical plane (V.P.) and parallel to the horizontal plane (H.P.). One side of the base is inclined at 45° to the horizontal plane (H.P.). [16]

Side of base = 30 mm and Length of Axis = 75 mm.

Use First angle method of projection.

Question 5

Refer to Figure 2 given below. It shows the Front View (F.V.) and the Right Hand Side View (R.H.S.V.) of an object in the third angle method of projection. Draw the OBLIQUE VIEW when the receding axis is inclined at 45° to the horizontal. [16]

(Do not insert any dimensions.)

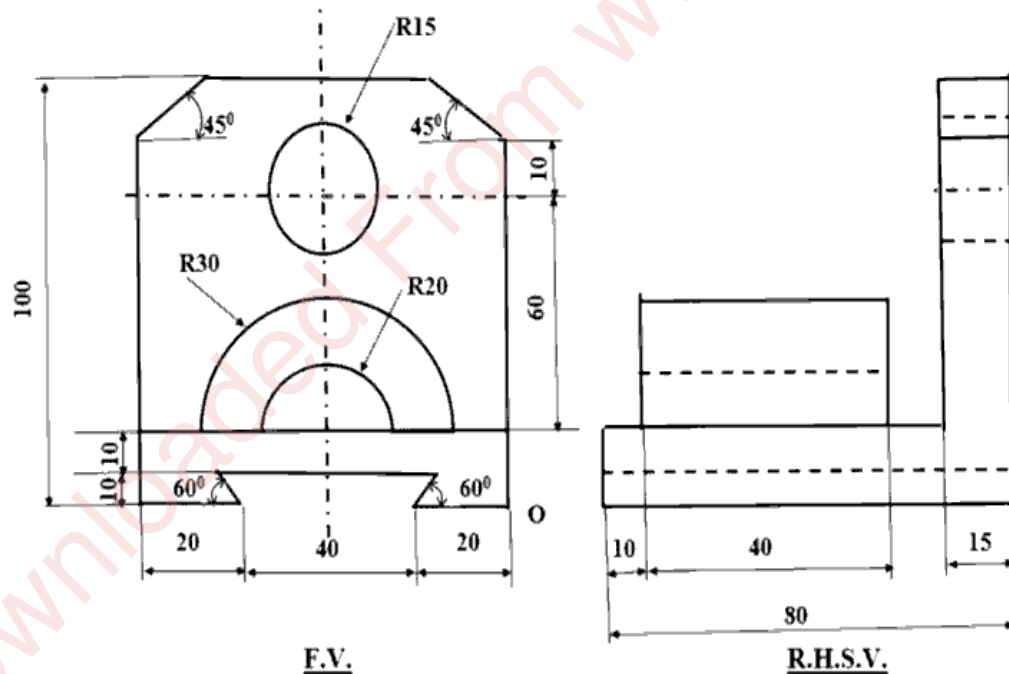

Figure 2

SECTION B (52 Marks)

Answer any **two** questions from this section.

Question 6

Refer to the Figure 3 given below.

[26]

Construct an Isometric Scale. Using the scale draw the Isometric Projection for the given isometric view.

(Do not insert any dimensions.)

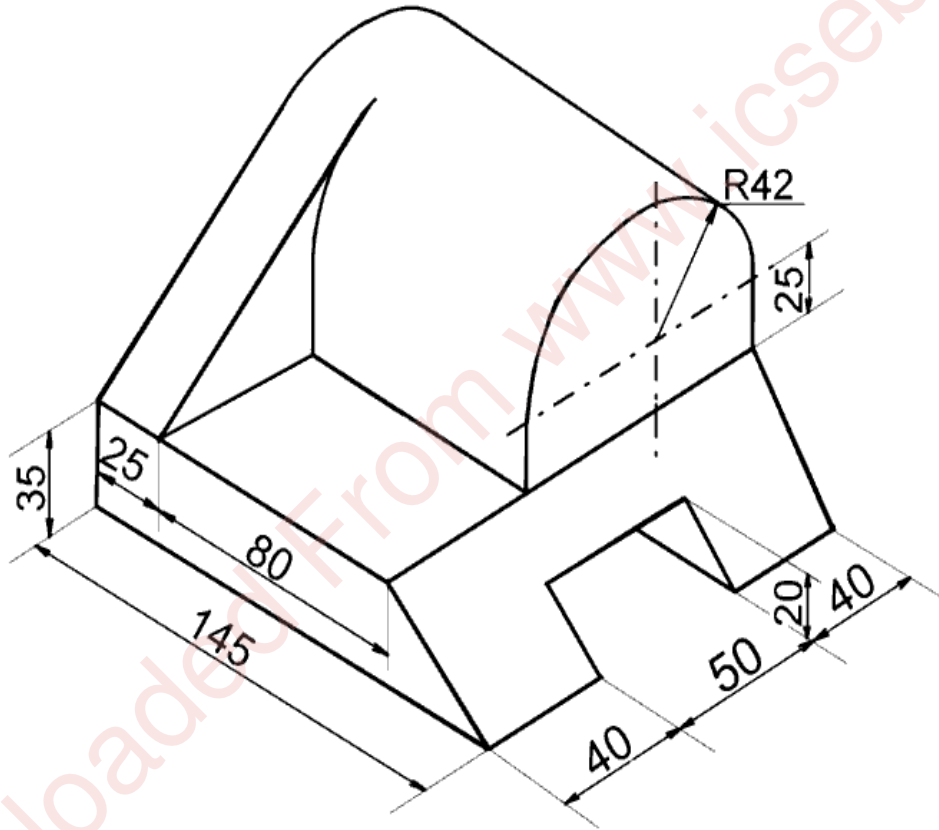

Figure 3

Question 7

Refer to Figure 4 given below. It shows the Front View (F.V.) and the Top View (T.V.) of a right circular cone in the first angle method of projection. Its axis is perpendicular to the Horizontal Plane (H.P.) and parallel to the Vertical Plane (V.P.). The cone is cut by a cutting plane which is perpendicular to the V.P. and inclined at 60° to the H.P. The Vertical Trace (V.T.) of the cutting plane is shown in the figure. [26]

Using First angle method of projections, draw the:

- (i) Front View
- (ii) Sectional Top View
- (iii) Development of the lateral surface of the remaining pyramid.
- (iv) True Shape of the section

Given: Diameter of the base = 64 mm

Slant height = 96 mm.

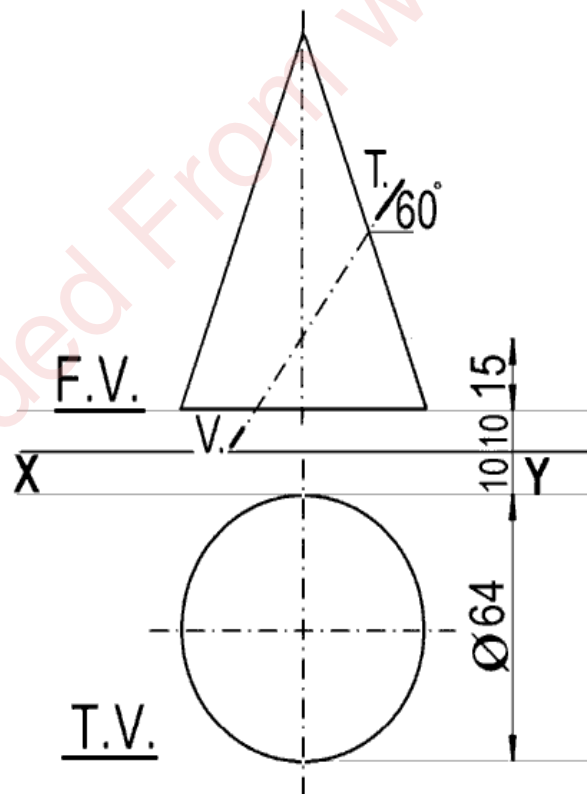

Figure 4

Question 8

Refer to Figure 5 given below.

[26]

Using the FIRST ANGLE METHOD of projection, draw the:

- (i) Sectional Front View [Section along A-A]
- (ii) Top View
- (iii) Right Hand Side View.

(Insert any six dimensions.)

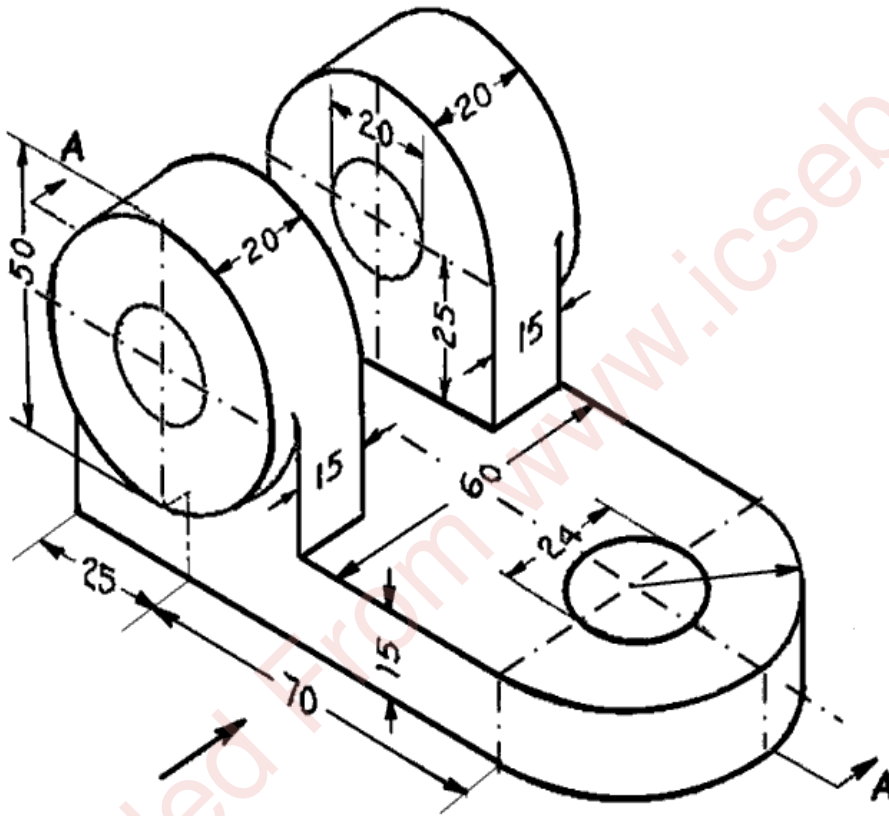

Figure 5