



## SECTION B – 55 MARKS

### Question 2

- (i) **Figure 2** given below shows the details of the components of an open bush bearing assembly used for supporting a ( stationary/ rotating) circular shaft without causing damage to the main body.

The bush (part 2, qty.1) is placed in the semi-circular cavity of the main body (part 1, qty. 1) having the radius of 21 mm. The thin part at the two ends of the bush (part 2, qty.1), having the radius of 30 mm remains outside the semi-circular cavity of the main body(part 2, qty 1).

This provides a locking arrangement to the bush and the main body.

- (a) Draw full size sectional elevation along A-B of the assembled components. [25]
- (b) Draw the plan (Top View) of the complete assembly omitting all hidden details. [10]
- (c) Draw the Left-hand Side View of the assembly omitting all hidden details. [10]
- (d) Make a neat parts list for all the components on your drawing sheet. [10]

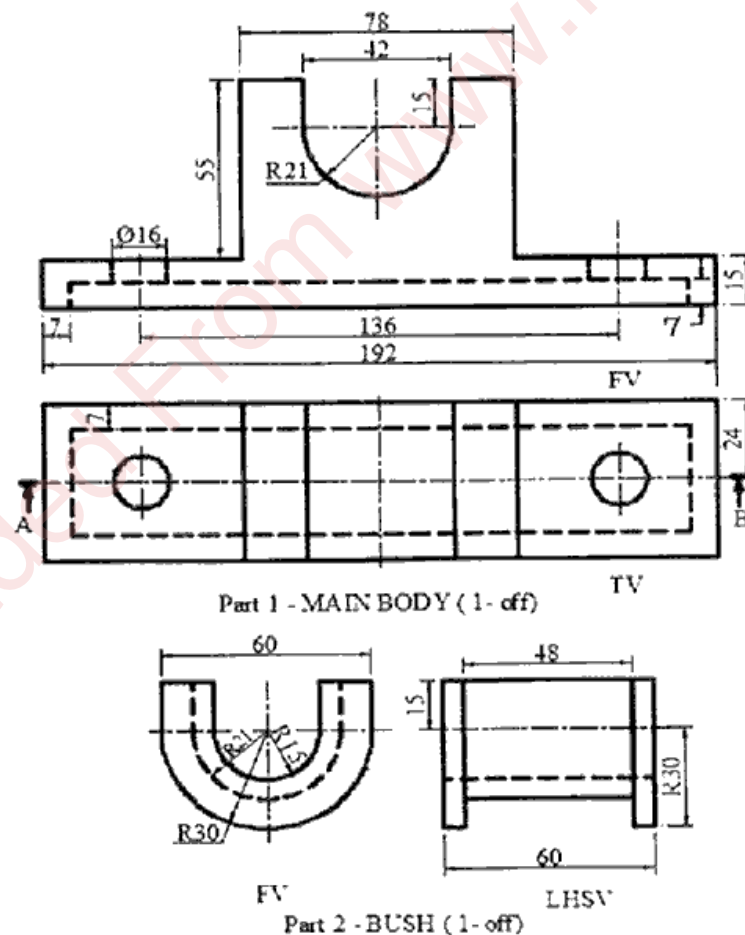

**Figure 2**

SECTION C – 55 MARKS

Question 3

- (i) *Figure 3* given below shows the isometric view of a machine block. Copy [20]  
the isometric view.

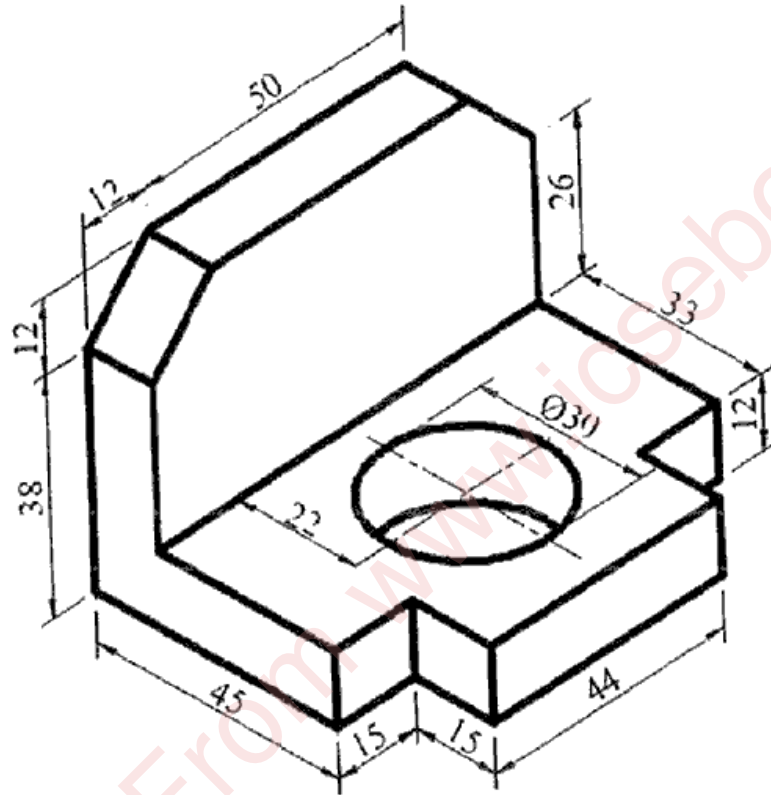
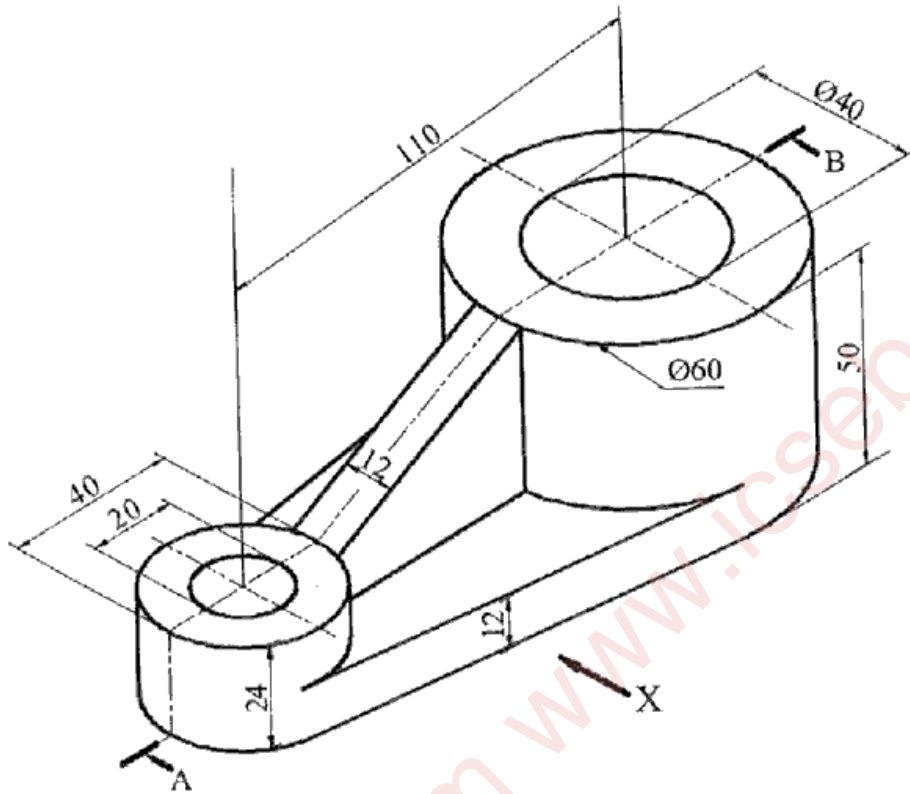

Figure 3

- (ii) *Figure 4* given below shows the machine block. Draw Sectional Front View (along A-B) and Top View by using first or third angle method of projection. [20]

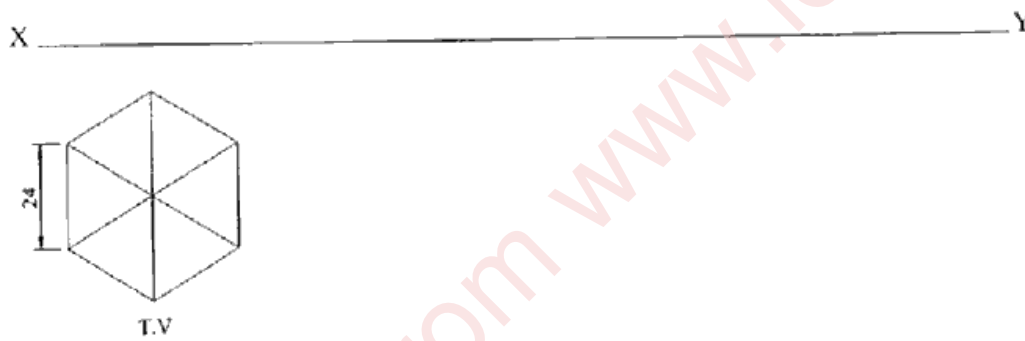

*Figure 4*

- (iii) **Figure 5** given below shows the Top View of a hexagonal base pyramid in first angle method of projection. Copy the given figure. Complete the Front View and draw the Front View and Top View if the axis of the pyramid is inclined at  $30^\circ$  to Horizontal Plane and Top View of the axis is inclined at  $45^\circ$  to Vertical Plane. [15]

Given:

Axis height = 60 mm



**Figure 5**